

DES00171



Sistemi di verniciatura industriale  
automatismi ed impianti

## User manual

### AS 100 Fluidity Indicator

[www.cmspray.it](http://www.cmspray.it) e-mail: [cmspray@cmspray.it](mailto:cmspray@cmspray.it)



### PERFORMANCE

- Accurate and quick measurement of the fluidity and of the ability of the powder to be fluidized
- Compact

### PRODUCTIVITY

- Helps determine the powder spraying parameters
- Quality management of powder batches

### SUSTAINABILITY

- Easy to clean
- Saves time for the commissioning of new powder paint facilities and/or new colors in the process

### USE

The powder is placed in suspension in the porous-bottomed cylinder, by means of a controlled air flow. Successively the height of fluidised powder bed is measured, in the fluidised state (H1), then the height at rest (H0) and the weight (P) of the fluidised powder that flows 30 s through the calibrated opening. It is thus possible to define a "projectability" factor, a characteristic of the powder:

$$R = P \times (H1 / H0)$$

For information, for epoxy powders with a density between 1.3 and 1.6, experience shows that results in function of R are as follows:

R	Rating
> 140	Very good
120 to 140	Good
80 to 120	limited
< 80	Poor

The AS100 fluidimeter demonstrates this behaviour and indicates immediately whether a powder is suitable for spraying purposes. It is a valuable aid in product quality control for both powder paint manufacturers and other laboratories. This is the first electrostatic powder coating apparatus to be covered by a registered French standard (T 30 A doc 396).

## TECHNICAL DATA

Description	AS100
Min. feed pressure (bar)	1
Maximum air flow (l/h)	500
Air inlet connector	fluted ø4 mm
Weight (kg)	5



Sistemi di verniciatura industriale  
automatismi ed impianti

[www.cmspray.it](http://www.cmspray.it) e-mail: [cmspray@cmspray.it](mailto:cmspray@cmspray.it)

## 1. Warning

This device complies with the French standards NF T30-500 and NF T30-501 and the standard ISO 8130-5.

**This device must be used outside explosive atmosphere zones. Due to the small quantity of powder used (250 g), no explosive atmosphere zone has to be considered when being used.**

## 2. Use

The device is a powder fluidity indicator. To date, there is no "benchmark" powder that would allow this indicator to be used a measuring instrument. It has been specially designed to qualify the suitability of powdered paints for spraying. It is well known that the electrostatic powder-coating process involves, on the one hand, suspending powdered paint in air to transport it and spray it onto the part and on the other, that different powdered paints react in significantly different ways when in suspension, depending on their particle size, the humidity, their formulation, etc.

The role of the **AS 100** is to characterise this behaviour by indicating whether or not the powdered paint is suitable for spraying. It constitutes a precious auxiliary device for product quality control laboratories, both for the powdered paint manufacturer and for the user.

## 3. Characteristics

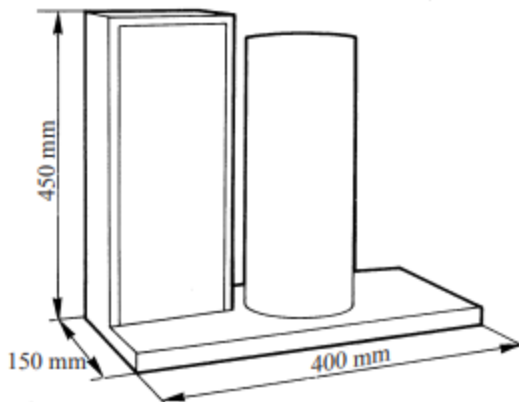

DIES00172

Minimum supply pressure	1 bar
Maximum air-flow rate	500 litres/hour
Weight	5 kg.

## 4. Description and connection

The **AS 100** has 9 component parts:

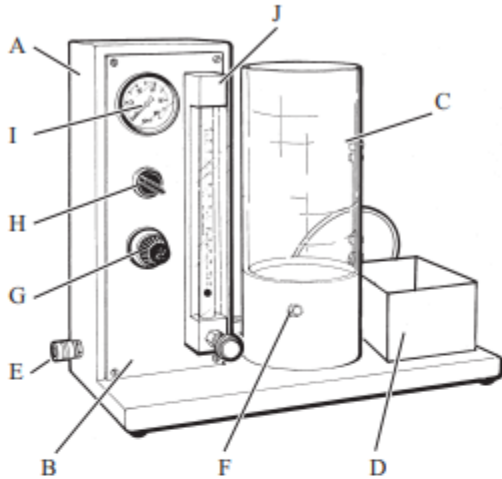

DES00170

A	Metal housing
B	Supporting the control panel
C	Fluidised powder tank
D	Measured powder container
E	Quick-disconnect air-supply union.
F	Powder tank air union
G	Air pressure regulator
H	Air pressure control valve
I	Control air pressure gauge



**WARNING :** Make sure that the regulator is unscrewed before introducing compressed air. If the pressure is too high, the pressure gauge (I) may be destroyed (100 mB maximum).

### 4.1. Description and Operation

#### 4.1.1. Fluidisation Chamber

The fluidisation chamber consists of:

- An aluminium base with a connection for the air supply and a fluidisation plate fixed to the bottom.
- An upper section in Plexiglas with a 4 mm-diameter calibrated port and a system for closing it.

#### 4.1.2. Powder Container

The powder container collects the powder coming out of the calibrated port.

#### 4.1.3. Other useful Devices for Measuring

- A weighing scale accurate to 0.1 g (not supplied).
- A timer (not supplied).
- A ruler graduated in mm.

## 5. Start-up

- After placing the device on a perfectly flat surface, make sure that the air valve is closed (button turned to the left), that the regulator is fully unscrewed and that the needle valve on the flow meter is closed.
- Connect the general air supply.
- Open the general air-supply valve (turn the button to the right).
- Open the flow meter valve by approximately half.
- Screw the button on the regulator until the ball in the flow meter comes to rest at the top end of the glass tube.
- Push the button on the regulator to lock it.

You are now familiar with the air controls on the device. It is now necessary to repeat the same adjustments but this time, introducing 250 g of the powder to be tested into the fluidisation chamber. Once the device has been adjusted, control the air flow using the flow meter valve.

## 6. Reading the Flow Meter and the Pressure Gauge

- The air flow meter is graduated according to a scale in millimetres. Use the following curve to convert the millimetres into litres/hour:

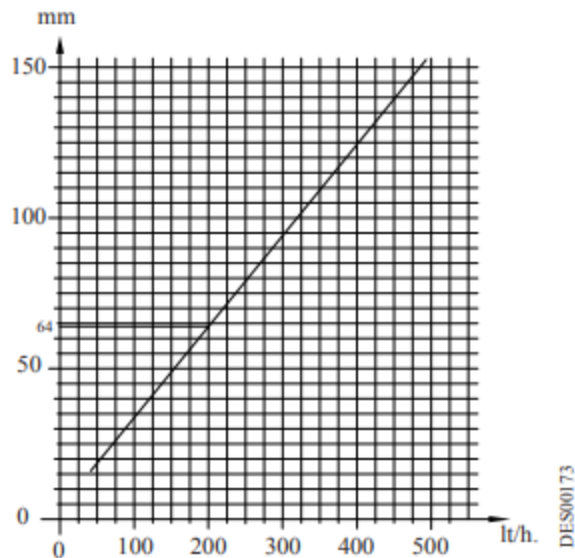

The reading is taken at the top of the ball.

The flow meter is usually used at approximately 20°° C and at a pressure similar to atmospheric pressure. The curve above can be used directly for converting litres/hour into millimetres. For example, to obtain 200 l/h, move the ball to 64 mm.

The pressure gauge indicates the pressure drop through the fluidisation plate.

## 7. Measurement method

The subsequent operations that have to be carried out to conduct a fluidisation measurement are as follows. For more details, refer to standards NF T30-500 and NF T30-501 or ISO 8130-5.

- With the side port closed, introduce 250 g of powder into the fluidisation cylinder.
- Fluidise the powder by admitting air under the porous bottom of the cylinder and set the air flow to 200 l/h. Help the powder to fluidise by stirring it with a spatula. Wait until the powder has reached its maximum level (1 to 2 minutes), then measure the height of the fluidised bed, H1.
- A flow rate of 200 l/h is usually suitable for fluidisation of thermosetting powders; other air flow rates may nevertheless be used when using different powders.

**Note: To measure the height of the fluidised bed, use a metal ruler stuck into the bed of powder until it touches the porous bottom. Remove it and read the height directly thanks to the film of powder remaining on its surface.**

- Cut off the air supply, wait until the bed of powder has settled down (approximately 1 to 2 minutes) and measure the new height, H0.
- Fluidise the bed of powder again, helping fluidisation with a spatula as indicated in 6.2, wait until the powder has reached its maximum level and then open the side port on the cylinder, switching on the timer at the same time. Let the powder run into the container for 30 seconds. Close the port.
- Weigh the powder collected in the container.
- Repeat the operations described in 6.4 and 6.5 three times, that is to say, note the weights of the powder collected, m1, m2 and m3.

## 8. Interpretation of results

The spraying suitability factor R is defined by the expression:

$$R = m \times (H1 / H0)$$

In which m is the arithmetical average of the weights of powder previously collected (m1, m2 and m3). As an indication, for epoxy powders with a density of 1.3 to 1.6, experience shows that the results according to R are usually the following:

R	Rating
> 140	Very good.
120 to 140	Good.
80 to 120	Poor.
< 80	Bad.

These are only simple indications and they remain subject to numerous parameters. According to his particular circumstances, each user can draw up a correspondence table that suits his requirements more precisely.